

110 MHz RGB Video Amplifier System with OSD

General Description

The LM1279 is a full featured and low cost video amplifier with OSD (On Screen Display). 8V operation for low power and increased reliability. Supplied in a 20-pin DIP package, accommodating very compact designs of the video channel requiring OSD. All video functions controlled by 0V to 4V high impedance DC inputs. This provides easy interfacing to 5V DACs used in computer controlled systems and digital alignment systems. Unique OSD switching, no OSD switching signal required. An OSD signal at any OSD input typically switches the LM1279 to the OSD mode within 5 ns. Ideal video amplifier for the low cost OSD monitor with resolutions up to 1280 x 1024. The LM1279 provides superior protection against ESD. Excellent alternative for the MC13282 in new designs.

Features

- Three wideband video amplifiers 110 MHz @ -3dB (4 V_{PP} output)
- OSD signal to any OSD input pin automatically switches all 3 outputs to the OSD mode

- Fast OSD switching time, typically 5 ns
- 3.5 kV ESD protection
- Fixed cutoff level typically set to 1.35V
- 0V to 4V, high impedance DC contrast control with over 40 dB range
- 0V to 4V, high impedance DC drive control (0 dB to -12 dB range)
- Matched (± 0.3 dB or 3.5%) attenuators for contrast control
- Output stage directly drives CRT drivers
- Ideal combination with LM2407 CRT driver

Applications

- High resolution RGB CRT monitors
- Video AGC amplifiers
- Wideband amplifiers with contrast and drive controls
- Interface amplifiers for LCD or CCD systems

Block and Connection Diagram

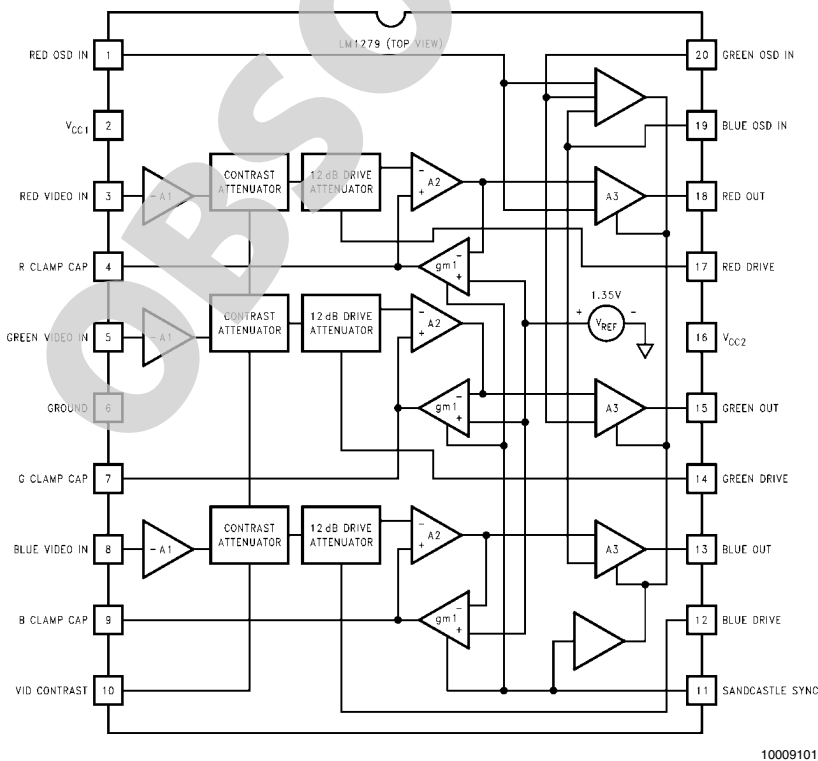

FIGURE 1. Order Number LM1279N
See NS Package Number N20A

Absolute Maximum Ratings (Note 1)

If Military/Aerospace specified devices are required, please contact the National Semiconductor Sales Office/Distributors for availability and specifications.

Supply Voltage		
Pins 2 and 16 (Note 3)	10V	
Peak Video Output Source Current		
(Any One Amp) Pins 13, 15, or 18	28 mA	
Voltage at Any Input Pin (V_{IN})	$V_{CC} \geq V_{IN} \geq GND$	
Power Dissipation (P_D)		
(Above 25°C Derate Based on θ_{JA} and T_J)	2.1W	
Thermal Resistance to Ambient (θ_{JA})	60°C/W	

Thermal Resistance to Case (θ_{JA})	37°C/W
Junction Temperature (T_J)	150°C
ESD Susceptibility (Note 4)	3.5 kV
ESD Machine Model (Note 16)	300V
Storage Temperature	-65°C to 150°C
Lead Temperature (Soldering, 10 sec.)	265°C

Operating Ratings (Note 2)

Temperature Range	0°C to 70°C
Supply Voltage (V_{CC})	$7.5V \leq V_{CC} \leq 8.5V$

DC Electrical Characteristics

$T_A = 25^\circ\text{C}$; $V_{CC1} = V_{CC2} = 8\text{V}$; $V_{10} = 4\text{V}$; $V_{Drive} = 4\text{V}$; $V_{11} = 7\text{V}$; $V_{OSD} = 0\text{V}$; $R_L = 390\Omega$ unless otherwise stated.

Symbol	Parameter	Condition	Typical (Note 5)	Limit (Note 6)	Units
I_S	Supply Current	$I_{CC1} + I_{CC2} - I_{Load}$ (Note 7)	80	90	mA(max)
$V_{3,5,8}$	Video Amplifier Input Bias Voltage		2.5		V
R_{IN}	Video Input Resistance	Any One Amplifier	20		k Ω
V_{11off}	Sandcastle Off Voltage		1.4	1.2	V (max)
$V_{11blank}$	Sandcastle Blank Voltage	Start of Blank Region	1.4	1.7	V (min)
$V_{11blank}$	Sandcastle Blank Voltage	End of Blank Region	2.8	3.2	V (max)
$V_{11clamp \& Blank}$	Sandcastle Clamp and Blank On Voltage	Start of Clamp and Blank Region	3.2	3.6	V (min)
$V_{11clamp \& Blank}$	Sandcastle Clamp and Blank On Voltage	End of Clamp and Blank Region	6.2	5.8	V (max)
$V_{11clamp}$	Sandcastle Clamp On/Blank Off Voltage	Clamp Only Region, Max = V_{CC}	6.2	6.5	V (min)
I_{11off}	Sandcastle Off Current	$V_{11} = 0\text{V}$	-5.0	-8.0	μA (max)
I_{11test}	Sandcastle Clamp On/Blank Off Curr	$V_{11} = 6.5\text{V}$	-100	-500	nA(max)
I_{clamp}	Clamp Cap Charge Current	Clamp Comparators On	± 750	± 500	μA (min)
I_{bias}	Clamp Cap Bias Discharge Current	Clamp Comparators Off	50	200	nA (max)
V_{OL}	Video Black Level	$V_{Video\ in} = 0\text{V}$, $V_{11} = 6.5\text{V}$	1.35	1.55	V (max)
ΔV_{OL}	Video Δ Black Level Output Voltage	Between Any Two Amplifiers	± 50	± 200	mV (max)
V_{OH}	Video Output High Voltage	$V_{11} < 1.2\text{V}$	5.0	4.6	V (min)
$I_{10, 12, 14, 17}$	Contrast/Drive Control Input Current	$V_{Contrast} = V_{Drive} = 0\text{V to } 4\text{V}$	-0.25	-1.5	μA (max)
$I_{11, 19i, 20i}$	OSD Low Input Current (each)	$V_{OSD\ in} = 0\text{V}$	-2.5	-10.0	μA (max)
$I_{1h, 19h, 20h}$	OSD High Input Current (each)	$V_{OSD\ in} = 5\text{V}$	100	130	μA (max)
$V_{OL}(\text{Blank})$	Video Output during Blanking	$V_{11} = 1.7\text{V}$	0.1	0.5	V (max)

AC Electrical Characteristics

$T_A = 25^\circ\text{C}$; $V_{CC1} = V_{CC2} = 8\text{V}$. Manually adjust Video Output pins 13, 15, and 18 to 4V DC for the AC test unless otherwise stated. (Note 15)

Symbol	Parameter	Conditions	Typical (Note 5)	Limit (Note 6)	Units
A_{Vmax}	Video Amplifier Gain	$V_{10} = 4\text{V}$, $V_{IN} = 635\text{ mV}_{PP}$	6.8	5.9	V/V (min)
		$V_{drive} = 4\text{V}$	16.7	15.4	dB (min)
ΔA_{V2V}	Contrast Attenuation @ 2V	Ref: A_V max, $V_{10} = 2\text{V}$	-6		dB
$\Delta A_{V0.25V}$	Contrast Attenuation @ 0V	Ref: A_V max, $V_{10} = 0\text{V}$	-35		dB
$\Delta Drive$	Drive Control Range	$V_{drive} = 0\text{V to } 4\text{V}$, $V_{10} = 4\text{V}$	12		dB
$A_{V\ match}$	Absolute Gain Match @ A_V max	$V_{10} = 4\text{V}$, $V_{drive} = 4\text{V}$ (Note 9)	± 0.3		dB

Symbol	Parameter	Conditions	Typical (Note 5)	Limit (Note 6)	Units
$A_{V \text{ track}}$	Gain Change Between Amplifiers	$V_{10} = 4V \text{ to } 2V$ (Note 9, Note 10)	± 0.3		dB
$f(-3 \text{ dB})$	Video Amplifier Bandwidth (Note 11, Note 12)	$V_{10} = 4V$, $V_{\text{drive}} = 4V$, $V_O = 3.5 V_{P-P}$	110		MHz
$t_r(\text{Video})$	Video Output Rise Time	$V_O = 3.5 V_{P-P}$ (Note 11)	3.6		ns
$t_f(\text{Video})$	Video Output Fall Time	$V_O = 3.5 V_{P-P}$ (Note 11)	3.2		ns
$V_{\text{sep}} 10 \text{ kHz}$	Video Amplifier 10 kHz Isolation	$V_{10} = 4V$ (Note 13)	-70		dB
$V_{\text{sep}} 10 \text{ MHz}$	Video Amplifier 10 MHz Isolation	$V_{10} = 4V$ (Note 11, Note 13)	-50		dB
$\Delta V_{OL}(\text{OSD})$	OSD Black Level, Difference from Video Black Level	$V_{\text{OSD in}} = 0.8V$, OSD Mode	-0.4	-0.7	V (max)
$V_{OH}(\text{OSD})$	OSD Output High Voltage (above measured video black level)	$V_{\text{OSD in}} = 2.5V$, OSD Mode	2.1	2.4	V (max)
$t_r(\text{OSD})$	Going into OSD Mode	OSD Mode (Figure 2)	5.0		ns
$t_f(\text{OSD})$	Going out of OSD Mode	OSD Mode (Figure 2)	10.0		ns
$t_{r\text{-prop}}(\text{OSD})$	Starting OSD Propagation Delay	Switching to OSD Mode (Figure 3)	13.0		ns
$t_{f\text{-prop}}(\text{OSD})$	Ending OSD Propagation Delay	Switching to Vid. Mode (Figure 3)	14.0		ns
$T_{pw}(\text{Clamp})$	Input Clamp Pulse Width (Part of Sandcastle Sync)	(Note 14)		200	ns (min)

Note 1: Absolute Maximum Ratings indicate limits beyond which damage to the device may occur.

Note 2: Operating Ratings indicate conditions for which the device is functional, but do not guarantee specific performance limits. For guaranteed specifications and test conditions, see the Electrical Characteristics. The guaranteed specifications apply only for the test conditions listed. Some performance characteristics may degrade when the device is not operated under the listed test conditions.

Note 3: V_{CC} supply pins 2 and 16 must be externally wired together to prevent internal damage during V_{CC} power on/off cycles.

Note 4: Human body model, 100 pF discharged through a 1.5 k Ω resistor.

Note 5: Typical specifications are specified at +25°C and represent the most likely parametric norm.

Note 6: Tested limits are guaranteed to National's AOQL (Average Outgoing Quality Level).

Note 7: The supply current specified is the current for V_{CC1} and V_{CC2} minus the current through R_L ($I_{\text{supply}} = I_{CC1} + I_{CC2} - I_L$). The supply current for V_{CC2} (pin 16) does depend on the output load. With video output at 1V DC, the additional current through V_{CC2} is 7.7 mA with $R_L = 390\Omega$.

Note 8: Output voltage is dependent on load resistor. Test circuit uses $R_L = 390\Omega$.

Note 9: Measure gain difference between any two amplifiers. $V_{IN} = 635 \text{ mV}_{PP}$.

Note 10: $\Delta A_{V \text{ track}}$ is a measure of the ability of any two amplifiers to track each other and quantifies the matching of the three attenuators. It is the difference in gain change between any two amplifiers with the contrast voltage (V_{10}) at either 4V or 2V measured relative to an A_V max condition, $V_{10} = 4V$. For example, at A_V max the three amplifiers' gains might be 17.1 dB, 16.9 dB, and 16.8 dB and change to 11.2 dB, 10.9 dB and 10.7 dB respectively for $V_{10} = 2V$. This yields the measured typical ± 0.1 dB channel tracking.

Note 11: When measuring video amplifier bandwidth or pulse rise and fall times, a double sided full ground plane printed circuit board without socked is recommended. Video amplifier 10 MHz isolation test also requires this printed circuit board. The reason for a double sided full ground plane PCB is that large measurement variations occur in single sided PCBs.

Note 12: Adjust input frequency from 10 MHz (A_V max reference level) to the -3 dB corner frequency ($f_{-3 \text{ dB}}$).

Note 13: Measure output levels of the other two undriven amplifiers relative to the driven amplifier to determine channel separation. Terminate the undriven amplifier inputs to simulate generator loading. Repeat test at $f_{IN} = 10 \text{ MHz}$ for $V_{\text{sep}} 10 \text{ MHz}$.

Note 14: A minimum pulse width of 200 ns is guaranteed for a horizontal line of 15 kHz. This limit is guaranteed by design. If a lower line rate is used then a longer clamp pulse may be required.

Note 15: During the AC test the 4V DC level is the center voltage of the AC output signal. For example, if the output is 4 V_{PP} the signal will swing between 2V DC and 6V DC.

Note 16: Machine Model ESD test is covered by specification EIAJ IC-121-1981. A 200 pF cap is charged to the specified voltage, then discharged directly into the IC with no external series resistor (resistance of discharge path must be under 50 Ω).

Timing Diagrams

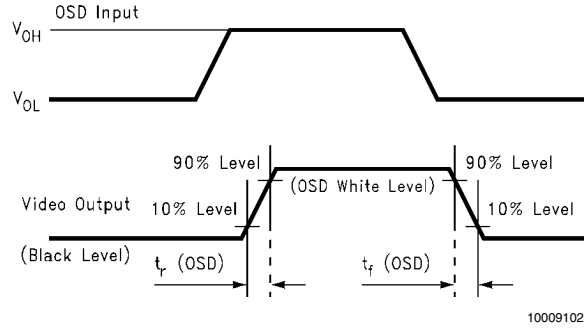

FIGURE 2. OSD Rise and Fall Times

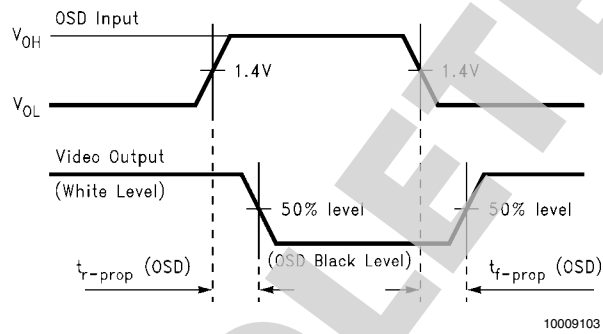

FIGURE 3. OSD Propagation Delays

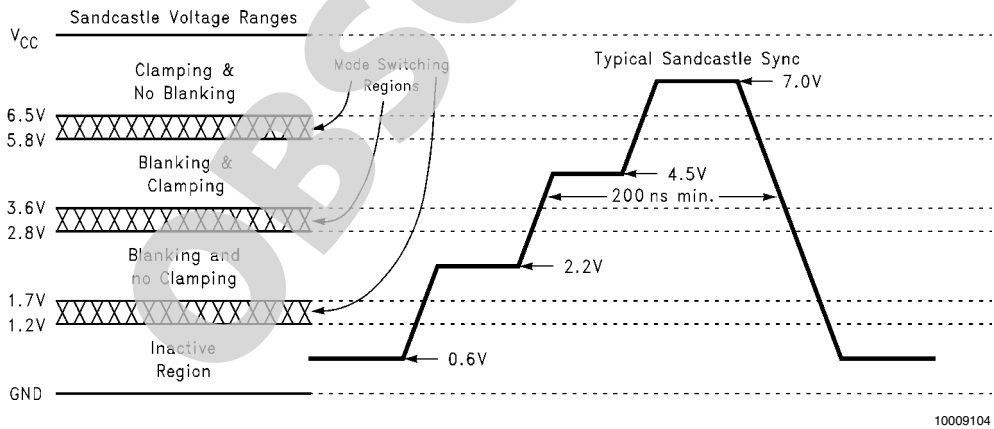
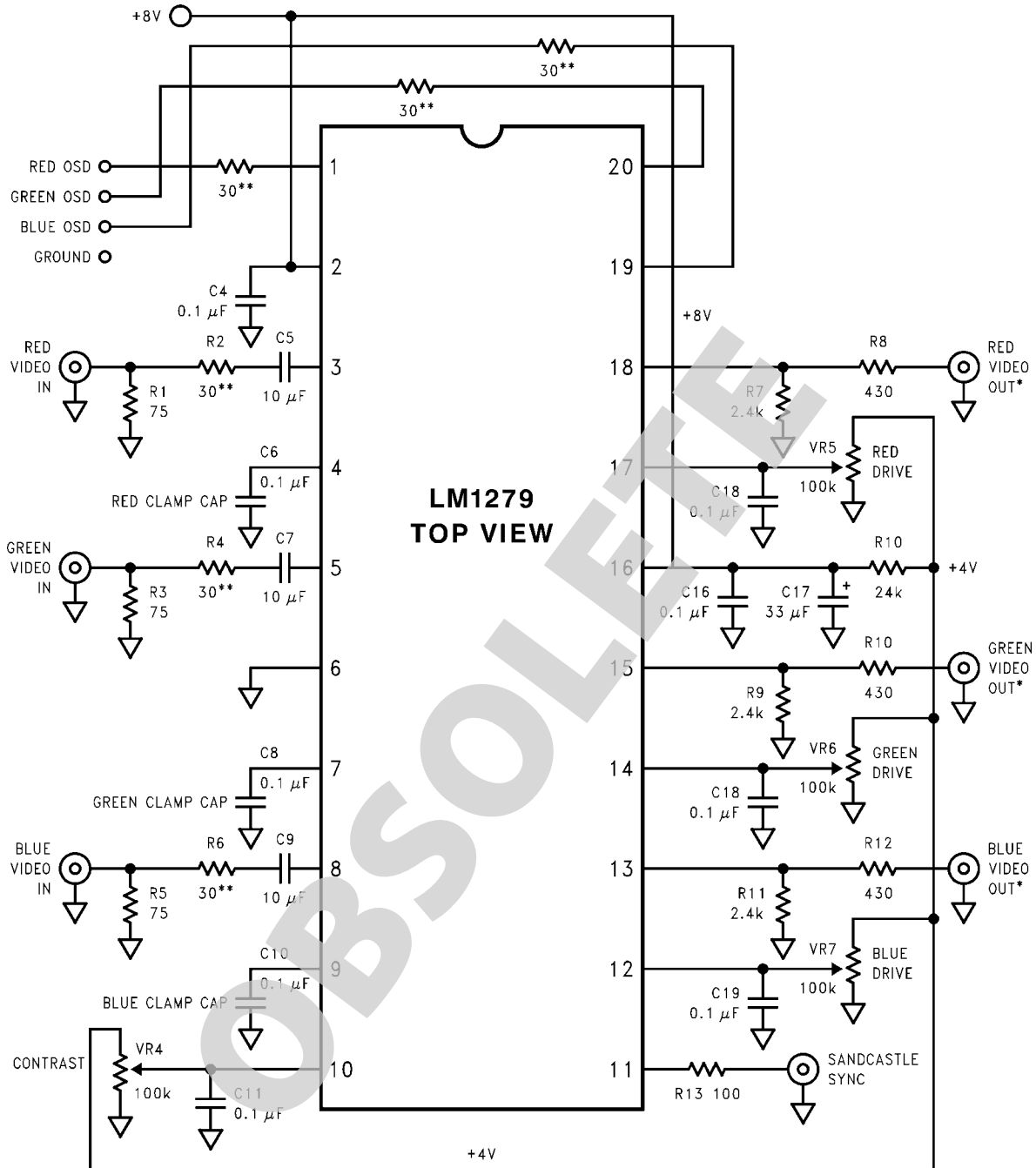

FIGURE 4. Sandcastle Sync Pulse

Test Circuits



*50Ω Termination to be Used at the Outputs

10009105

****Note:** All video inputs *must* have a series 30Ω resistor for protection against EOS (Electrical Over Stress). If the OSD signals are external to the monitor, and these signals are present any time when +8V is not fully powered up, then the OSD inputs also *require* a series 30Ω resistor.

FIGURE 5. LM1279 OSD Video Pre-amp Demonstration Board Schematic

Pin Descriptions

Pin No.	Pin Name	Schematic	Description
1 19 20	Red OSD Input Blue OSD Input Green OSD Input		These are standard TTL inputs. An OSD signal at any of the three pins will automatically switch the pre-amp into the OSD mode. 7 colors, including white, are available.
2	V _{CC1}		Power supply pin (excluding output stage)
3 5 8	Red Video In Green Video In Blue Video In		Video inputs. These inputs <i>must</i> be AC Coupled with a minimum of a 1 μ F cap, 10 μ F is preferred. A series resistor of about 33 Ω must be used for ESD protection.
4 7 9	Red Clamp Cap Green Clamp Cap Blue Clamp Cap		The external clamp cap is charged and discharged to the correction voltage needed for DC restoration. 0.1 μ F is the recommended value.
6	Ground		Ground pin.
10 12 14 17	Contrast Blue Drive Green Drive Red Drive		Contrast control pin: 4V - no attenuation 0V - over 40 dB attenuation Drive control pins: 4V - no attenuation 0V - 20 dB attenuation
11	Sandcastle Input		The sandcastle input allows for blanking only, or blanking with DC restoration. Blanking requires a 2V input. Clamping with blanking requires a 4V input.

Pin No.	Pin Name	Schematic	Description
13 15 18	Blue Video Out Green Video Out Red Video Out		Video output. For proper black level the output must drive 390Ω impedance.
16	V _{CC2}		Power supply pin for the output stage. There are no internal connections to V _{CC1} .

ESD and Arc-Over Protection

The ESD cells of the LM1279 are improved over the ESD cells used in typical video pre-amps. The monitor designer must still use good PC board layout techniques when designing with the LM1279. The human body model ESD susceptibility of these parts is rated at 3 kV (Note 4). However, many monitor manufacturers are now testing their monitors to the level 4 of the IEC 801-2 specification. This requires the inputs to the monitor to survive an 8 kV discharge. If the monitor designer expects to survive such levels he MUST provide external ESD protection to the video pre-amp inputs! PC board layout is very important with LM1279 as with other video pre-amps. The LM1279 provides excellent protection against ESD and arc-over, but the LM1279 is not a substitute for good PCB layout.

Figure 6 shows the recommended input protection for a video pre-amp. The two diodes at the video pre-amp input and after the 30Ω series resistor offers the best protection against ESD. When this protection is combined with a good PCB layout, the video pre-amp will easily survive the IEC 801-2 level 4 (8 kV ESD) testing commonly done by monitor manufacturers. If the protection diodes are moved to the video input side of the 30Ω resistor, then the ESD protection will be less effective. There is also the risk of damaging the diodes since there is no resistor for current limiting. In such a design a heavier duty diode, such as the FDH400, should be used. It is strongly recommended that the protection diodes be added as shown in Figure 6. The 1N4148 diode has a maximum capacitance of 4 pF. This would have little effect on the response of the video system due to the low impedance of the input video.

Many monitor designers prefer to use a single zener diode instead of the recommended two diodes at the video pre-amp input. The required location of the zener diode is shown in Figure 6. It is shown as a dashed line, indicating an alternative to the two diode solution. The zener diode does give the savings of one component, but now the protection is less effective. To minimize capacitance, the zener diode needs to have a zener voltage of 24V or higher. This is well above the V_{CC} voltage of the LM1279. The zener diode must be located at the video input for protection against a low voltage surge. The 30Ω resistor is needed to limit the current of such a voltage surge, protecting the video pre-amp. Protection against ESD by using a zener diode is about as effective as having the two diodes at the video input (same location as the zener diode). A higher series resistor may be necessary for protection against the zener voltage, but the higher resistor value will impair the performance of the LM1279; resulting in a lower bandwidth and a less stable black level. For maximum reliability the monitor designer should not consider the zener diode solution for ESD protection of the LM1279.

The ESD cells of the LM1279 also gives good tolerance against arc-over. Once again the monitor designer must be careful in his PCB layout for good arc-over protection. In the video chain only the outputs of the CRT driver are directly exposed to the voltages that may occur during arc-over. A good PCB layout is the best protection for the video pre-amp against arc-over. The pre-amp vulnerability is mainly through the ground traces on the PCB. For proper operation all ground connections associated with the video pre-amp, including the grounds to the bypass capacitors, must have short returns to the ground pins. A significant ground plane should be used to connect all the pre-amp grounds. Figure 16, the demo board layout, is an excellent example on an effective ground plane, yet using only a single sided PCB layout. Here is a check list to make sure a PC board layout has good grounding:

- All associated grounds with the video pre-amp are connected together through a large ground plane.
- CRT driver ground is connected to the video pre-amp ground at one point.
- CRT and arc protection grounds are connected directly to chassis, or the main ground. There is no arc-over current flow from these grounds through the pre-amp or CRT driver grounds.

If any one of the above suggestions are not followed, then the LM1279 may become vulnerable to arc-over. Improper grounding is by far the most common cause of a video pre-amp failure during arc-over.

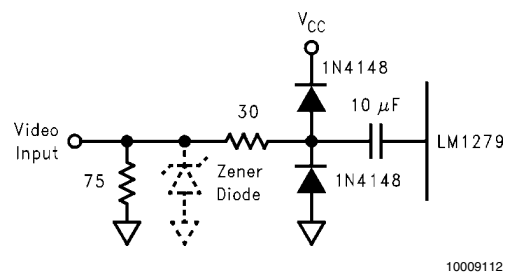

FIGURE 6. Recommended Video Input ESD Protection

Functional Description

Figure 1 on the front page shows the block diagram of the LM1279 along with the pinout of the IC. Each channel receives a video input signal at its input amplifier (-A1). The output of the input amplifier goes to the contrast attenuator stage. For easy interfacing to 5V DACs all controls inputs, including the contrast control, use a 0V to 4V range. The contrast control has no attenuation with an input of 4V, and has full attenuation (over -40 dB) with a 0V input. All three channels will accurately track the contrast control setting at pin 10.

Each channel will have the same amount of attenuation for a given input voltage typically to within ± 0.3 dB. All channels will track because the contrast control is the first stage of attenuation and the internal control voltage generated from the input voltage is common to all three channels.

The output of the contrast attenuator goes to the drive attenuator. This stage has a 12 dB control range. This stage is used for color balance, so the adjustment range has been limited to 12 dB for a more accurate color balance. Each channel has its own independent control pin with the 0V to 4V control range. An input of 4V give no attenuation, and an input of 0V gives the full 12 dB attenuation.

The output of the drive attenuator stage goes to the inverting input of A2. Since this is the second inversion stage, the output of A2 will be the non-inverted video signal. Note that the output of gm1 goes to the non-inverting input of A2. Also note that the output of A2 goes to the inverting input of gm1. This is the feedback for the clamp circuitry. The output stage of A2 is an exact duplicate of the video output through A3. If a 390 Ω load impedance is used at the video output, then the black level at the output stage will accurately track the output of A2. The other input to gm1 is the desired black level output of the LM1279. Since the LM1279 has a fixed black level output, the non-inverting inputs to gm1 in all three channels go to a fixed 1.35V internal reference. This sets the black level output to a nominal 1.35V. gm1 acts like a sample and hold amplifier. Once the sandcastle sync exceeds 3.6V gm1 is activated, driving the input of A2 to a level where the video output will be 1.35V. For proper DC restoration it is important that gm1 be activated only during the horizontal flyback time when the video is at the black level. gm1 also charges the clamp cap to the correct voltage to maintain a 1.35V black level at the video output. When gm1 is turned off the voltage stored on the clamp cap will maintain the correct black level during the active video, thus restoring the DC level for a 1.35V black level.

The input of A3 receives the output from A2. The video channel of A3 is a duplication of the output stage to A2. As mentioned in the previous paragraph this is done so that the DC restoration can be done at the A2 stage. A3 also receives the OSD input and a sandcastle input for blanking. By doing DC restoration at the A2 stage, OSD or blanking can be activated at the output stage during the time DC restoration is being done at A2. There is an interface circuit between the sandcastle input and the A3 output stages. This interface circuit will activate the blanking if the sandcastle sync input is between 1.7V and 6.0V. The blanking mode will force the output down to a level of about 0.1V. This is a blacker-than-black level and can be used for blanking at the cathodes of the CRT.

Once the sandcastle exceeds 6.5V, then the output will no longer be in the blanked mode, but DC restoration is still being done on the video signal.

The OSD signal goes into a special interface circuit. The output of this circuit will drive the output of A3 to either an OSD black level or to about 2.4V above the video black level (OSD white level). The OSD black level is about 300 mV below the video black level. This guarantees that if the OSD signal is not activated for a particular channel, then its output will be slightly below the cutoff level. If an OSD input is received in a particular channel, then the video output will be at the OSD white level. The OSD mode is automatically activated if there is only one OSD signal to any of the video channels. This OSD control circuit will allow any color, except black, during the OSD mode. This also saves the need for a special signal to switch into the OSD mode. Remember that at least one OSD

input must be high to enable the OSD mode, therefore black can't be used in the OSD window.

SANDCASTLE SYNC

This special sync signal is used to allow for a 20-pin OSD video pre-amp with all the desired controls. By using a sandcastle sync, both clamping and blanking can be activated from the same pin. *Figure 4* shows the sandcastle sync signal. There are four possible modes of operation with the Sandcastle pulse. These modes are:

1. Inactive Region
2. Blanking and no Clamping
3. Blanking and Clamping
4. Clamping and no Blanking

Figure 4 also shows the voltage levels where the LM1279 switches from one mode to the other mode. As an example the LM1279 will switch from the inactive mode to the blanking and no clamping mode between 1.2V and 1.7V. For proper operation the inactive input must be safely below the 1.2V level. The blanking with no clamping pulse must be safely above 1.7V and below 2.8V. Blanking and clamping must be between 3.6V and 5.8V. Clamping and no blanking must be above 6.5V with the maximum voltage being limited by V_{CC} . If the monitor designer desires to blank at the cathode, then he would go into the blanking and no clamping mode for most of the flyback period. During this period it is also necessary to do DC restoration. During this time the LM1279 should be operated in the blanking and clamping mode. In this mode DC restoration is done without interfering with blanking.

In some designs the horizontal phase shift capability of the monitor is very large. In these designs the video can be moved so the flyback period can be displayed during the active trace period for the video. Now the clamping could be done during the normal video sweep time. During this period clamping with blanking will give a black bar on the CRT screen. This is not a normal operating mode of the monitor, but the monitor designer still may prefer not to display this black bar. Under this condition the clamp pulse must be above 6.5V.

A simple two transistor sandcastle generator is covered in separate application note. This circuit will generate all four states for the sandcastle sync, including the clamp with no blanking when the clamping function occurs during the period for active video. The switching time between the inactive region and the clamp only region must be less than 30 ns if complete elimination of any blanking pulse is required in an application.

Applications of the LM1279

Two demonstration boards are available to evaluate the LM1279. One board is the pre-amp demonstration board. This board was used for testing and characterizing the LM1279. The schematic for this board is shown in *Figure 5* and the printed circuit layout for this board is shown in *Figure 7*. The other board is a complete video channel neck board that can be directly plugged into the CRT socket. The schematic for this board is shown in *Figure 10* and the printed circuit layout is shown in *Figure 11*. The CRT driver used on this board is the LM2407. Any of National's monolithic CRT drivers can be used in this board, but the LM2407 is considered the best match to the LM1279 based on cost and performance.

Some important notes on *Figure 5*. All three video inputs have a 75 Ω terminating resistor for a 75 Ω video system. This is the normal video impedance of the video from a computer system. It is possible to also have a 50 Ω system, then R1, R3,

and R5 would be changed to 50Ω. R2, R4, and R6 are in series with the video inputs of the LM1279. These three 30Ω resistors are required to protect the IC from any sudden voltage surges that may result during the power up and power down modes, or when connecting the monitor to other equipment. The monitor designer must include these resistors in his design for good monitor reliability. If additional protection against ESD at the video inputs is necessary, then adding clamp diodes on the IC side of the 30Ω resistors is recommended, one to V_{CC1} and one to ground (see [Figure 6](#)). Sometimes a designer may want to increase the value of the 30Ω resistors at the video inputs, for additional ESD protection. This is not recommended with the LM1279. C5, C7, and C9 are part of the DC restoration circuit. This circuit is depending on a total maximum circuit resistance of about 110Ω; 30Ω input series resistor plus 75Ω for the video termination resistor. Increasing the value of the 30Ω resistors will exceed the 110Ω limit. The excellent internal ESD protection and the external clamp diodes (if needed) will provide excellent ESD protection.

The 30Ω resistors in series with the OSD inputs are also necessary if the OSD signals are external to the monitor, or if these signals are present any time when the +8V is not fully powered up. Interfacing to the OSD inputs is quite easy since the signal processing necessary to match the OSD signals to the video levels is done internal by the LM1279. There is also no need for an OSD window signal. Any time there is a high TTL signal at any of the three OSD inputs, the LM1279 will automatically switch to the OSD mode. A high TTL OSD signal will give a high video output for that color. The OSD level is fixed, typically 2.3V above the video black level. This will give a fixed brightness to the OSD window, but not at maximum video brightness which could be unpleasant to the user. [Figure 2](#) and [Figure 3](#) show the timing diagrams of the OSD signals for the LM1279.

The recommended load impedance for the LM1279 is 390Ω. However, some changes in the load impedance can be made. If the load impedance is reduced, the monitor designer must confirm that the part is still operating in its proper die temperature range, never exceeding a die temperature of 150°C.

When changing the load impedance, the black level shift is shown in the chart below. The measured V_{P-P} output with under 1% distortion is also listed.

Load	V_{P-P}	Blk. Level Shift
430Ω	3.62V	+15 mV
390Ω	3.62V	0 mV
330Ω	3.58V	-25 mV
270Ω	3.51V	-45 mV

When using a lower load impedance, the LM1279 does go into hard clipping more quickly. This does reduce the headroom of the video output.

Board layout is always critical in a high frequency application such as using the LM1279. A poor layout can result in ringing of the video waveform after sudden transitions, or the part could actually oscillate. A good ground plane and proper routing of the +8V are important steps to a good PCB layout. The LM1279 does require very good coupling between V_{CC1} and V_{CC2} (pins 2 and 16). This is clearly shown in [Figure 7](#) and [Figure 11](#) with the short and large trace between pins 2 and 16. Both demonstration boards offer the monitor designer an excellent example of good ground plane being used with the LM1279. These boards are single sided, yet allow the LM1279 to operate at its peak performance. The neck board also shows a good example of interfacing to a CRT driver and to the CRT. The video signal path is kept as short as possible between the LM1279 and the CRT driver, and also between the CRT driver and the CRT socket. Actual performance of the LM1279 in the video pre-amp demonstration board is shown in [Figure 8](#) and [Figure 9](#).

References

- Ott, Henry W. *Noise Reduction Techniques in Electronic Systems*, John Wiley & Sons, New York, 1976
- Zahid Rahim, "Guide to CRT Video Design," Application Note 861, National Semiconductor Corp., Jan. 1993

Applications of the LM1279

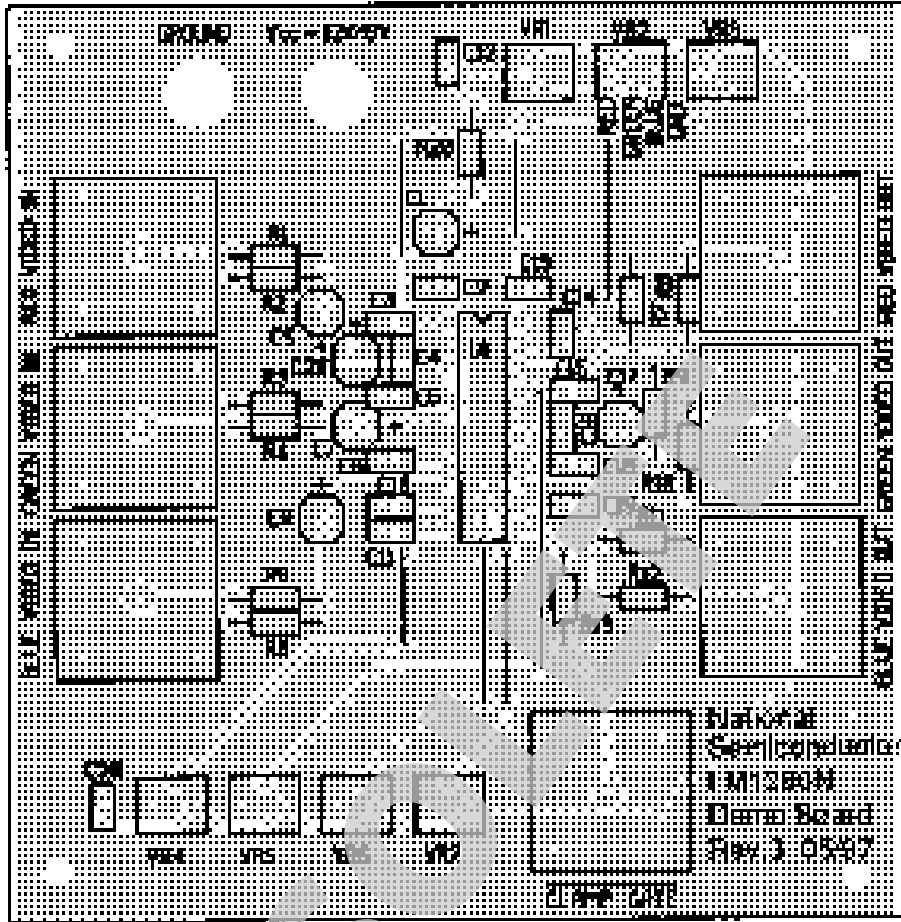

10009113

FIGURE 7. LM1279 OSD Video Pre-Amp Demonstration Board Layout

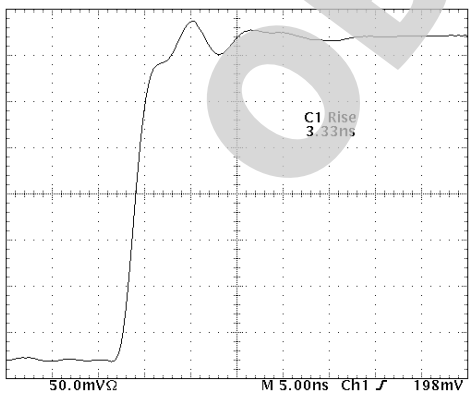

10009116

FIGURE 8. LM1279 Rise Time

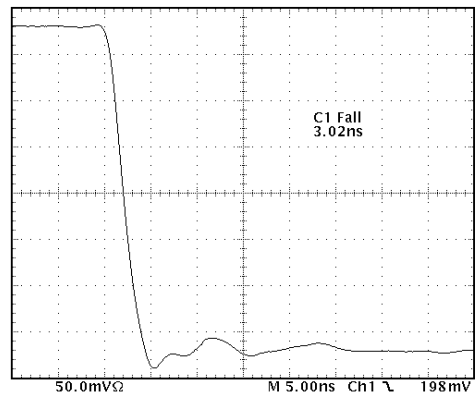

10009117

FIGURE 9. LM1279 Fall Time

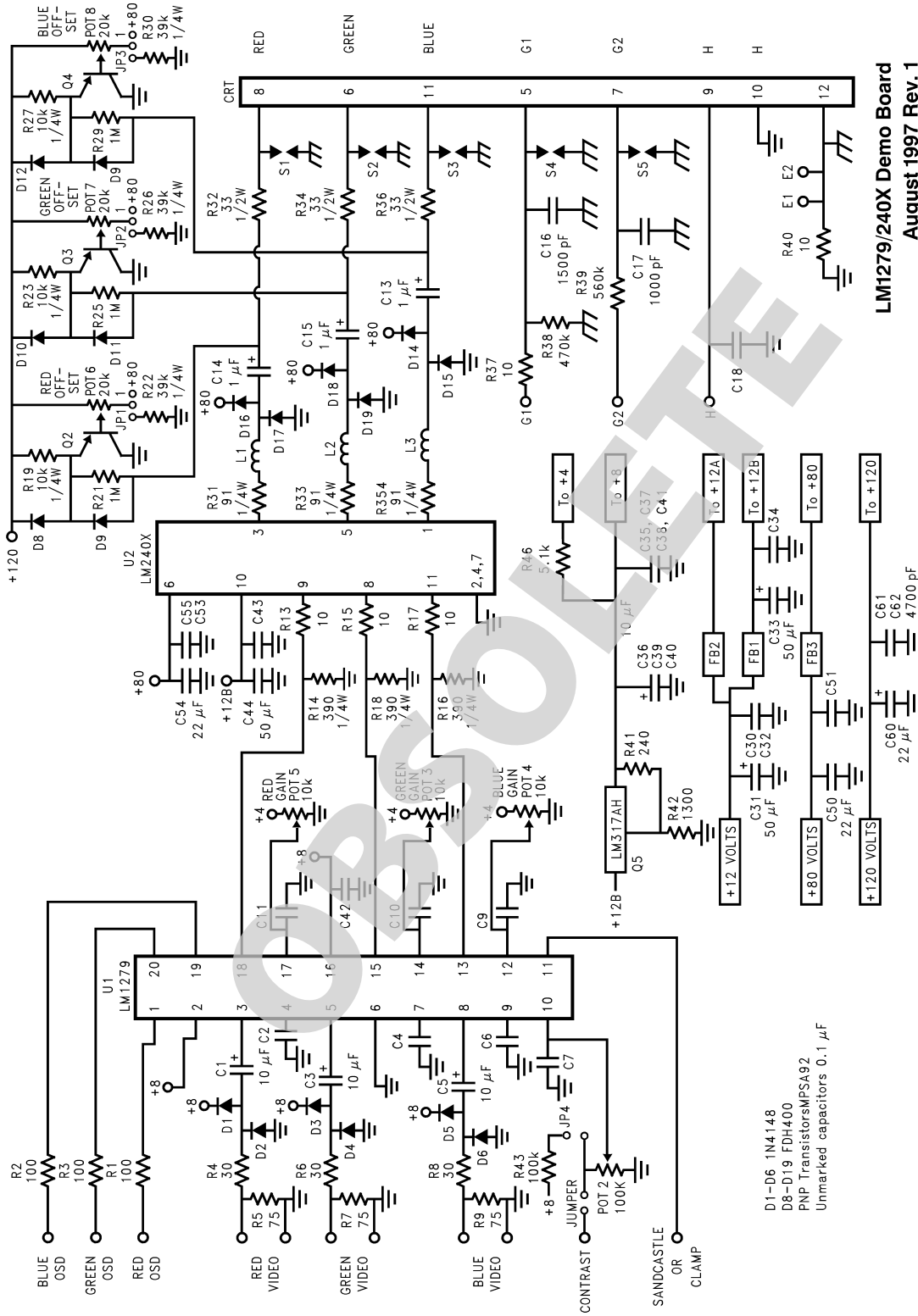

LM1279/240X Demo Board
August 1997 Rev. 1

10009114

FIGURE 10. LM1279/LM2407 Demonstration Neck Board Schematic

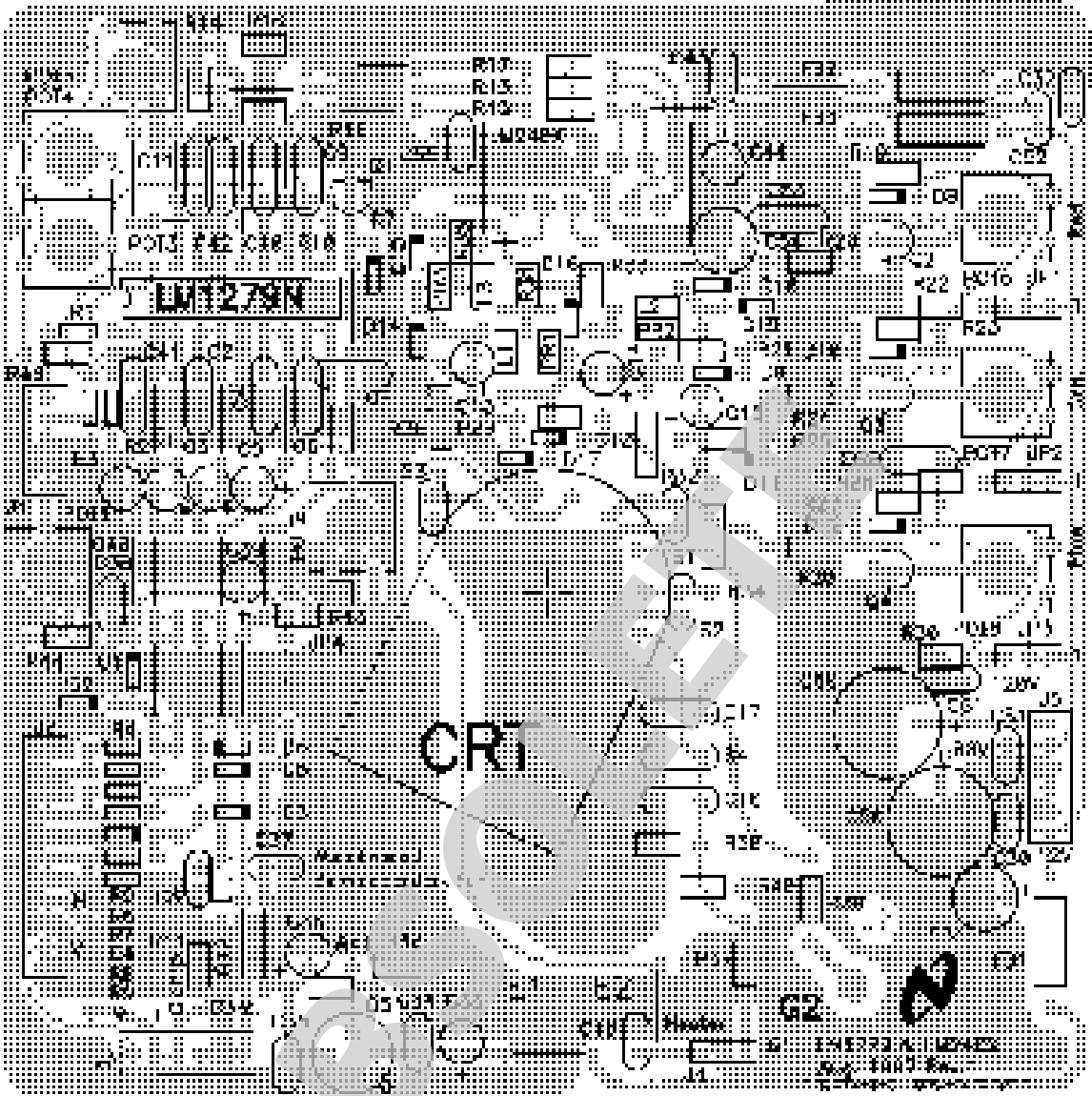

10009115

FIGURE 11. LM1279/LM2407 Demonstration Neck Board Layout

Physical Dimensions

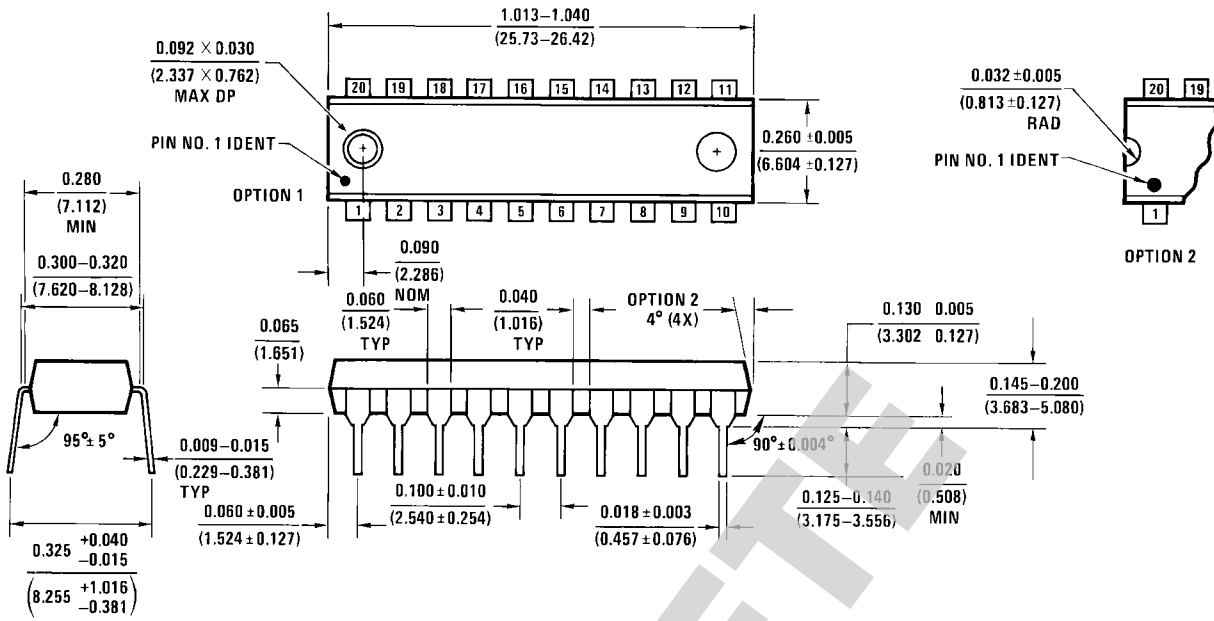
 inches (millimeters) unless otherwise noted

N20A (REV G)

Order Number LM1279N
NS Package Number N20A

Notes

For more National Semiconductor product information and proven design tools, visit the following Web sites at:
www.national.com

Products		Design Support	
Amplifiers	www.national.com/amplifiers	WEBENCH® Tools	www.national.com/webench
Audio	www.national.com/audio	App Notes	www.national.com/appnotes
Clock and Timing	www.national.com/timing	Reference Designs	www.national.com/refdesigns
Data Converters	www.national.com/adc	Samples	www.national.com/samples
Interface	www.national.com/interface	Eval Boards	www.national.com/evalboards
LVDS	www.national.com/lvds	Packaging	www.national.com/packaging
Power Management	www.national.com/power	Green Compliance	www.national.com/quality/green
Switching Regulators	www.national.com/switchers	Distributors	www.national.com/contacts
LDOs	www.national.com/ldo	Quality and Reliability	www.national.com/quality
LED Lighting	www.national.com/led	Feedback/Support	www.national.com/feedback
Voltage References	www.national.com/vref	Design Made Easy	www.national.com/easy
PowerWise® Solutions	www.national.com/powerwise	Applications & Markets	www.national.com/solutions
Serial Digital Interface (SDI)	www.national.com/sdi	Mil/Aero	www.national.com/milaero
Temperature Sensors	www.national.com/tempensors	SolarMagic™	www.national.com/solarmagic
PLL/VCO	www.national.com/wireless	PowerWise® Design University	www.national.com/training

THE CONTENTS OF THIS DOCUMENT ARE PROVIDED IN CONNECTION WITH NATIONAL SEMICONDUCTOR CORPORATION ("NATIONAL") PRODUCTS. NATIONAL MAKES NO REPRESENTATIONS OR WARRANTIES WITH RESPECT TO THE ACCURACY OR COMPLETENESS OF THE CONTENTS OF THIS PUBLICATION AND RESERVES THE RIGHT TO MAKE CHANGES TO SPECIFICATIONS AND PRODUCT DESCRIPTIONS AT ANY TIME WITHOUT NOTICE. NO LICENSE, WHETHER EXPRESS, IMPLIED, ARISING BY ESTOPPEL OR OTHERWISE, TO ANY INTELLECTUAL PROPERTY RIGHTS IS GRANTED BY THIS DOCUMENT.

TESTING AND OTHER QUALITY CONTROLS ARE USED TO THE EXTENT NATIONAL DEEMS NECESSARY TO SUPPORT NATIONAL'S PRODUCT WARRANTY. EXCEPT WHERE MANDATED BY GOVERNMENT REQUIREMENTS, TESTING OF ALL PARAMETERS OF EACH PRODUCT IS NOT NECESSARILY PERFORMED. NATIONAL ASSUMES NO LIABILITY FOR APPLICATIONS ASSISTANCE OR BUYER PRODUCT DESIGN. BUYERS ARE RESPONSIBLE FOR THEIR PRODUCTS AND APPLICATIONS USING NATIONAL COMPONENTS. PRIOR TO USING OR DISTRIBUTING ANY PRODUCTS THAT INCLUDE NATIONAL COMPONENTS, BUYERS SHOULD PROVIDE ADEQUATE DESIGN, TESTING AND OPERATING SAFEGUARDS.

EXCEPT AS PROVIDED IN NATIONAL'S TERMS AND CONDITIONS OF SALE FOR SUCH PRODUCTS, NATIONAL ASSUMES NO LIABILITY WHATSOEVER, AND NATIONAL DISCLAIMS ANY EXPRESS OR IMPLIED WARRANTY RELATING TO THE SALE AND/OR USE OF NATIONAL PRODUCTS INCLUDING LIABILITY OR WARRANTIES RELATING TO FITNESS FOR A PARTICULAR PURPOSE, MERCHANTABILITY, OR INFRINGEMENT OF ANY PATENT, COPYRIGHT OR OTHER INTELLECTUAL PROPERTY RIGHT.

LIFE SUPPORT POLICY

NATIONAL'S PRODUCTS ARE NOT AUTHORIZED FOR USE AS CRITICAL COMPONENTS IN LIFE SUPPORT DEVICES OR SYSTEMS WITHOUT THE EXPRESS PRIOR WRITTEN APPROVAL OF THE CHIEF EXECUTIVE OFFICER AND GENERAL COUNSEL OF NATIONAL SEMICONDUCTOR CORPORATION. As used herein:

Life support devices or systems are devices which (a) are intended for surgical implant into the body, or (b) support or sustain life and whose failure to perform when properly used in accordance with instructions for use provided in the labeling can be reasonably expected to result in a significant injury to the user. A critical component is any component in a life support device or system whose failure to perform can be reasonably expected to cause the failure of the life support device or system or to affect its safety or effectiveness.

National Semiconductor and the National Semiconductor logo are registered trademarks of National Semiconductor Corporation. All other brand or product names may be trademarks or registered trademarks of their respective holders.

Copyright© 2011 National Semiconductor Corporation

For the most current product information visit us at www.national.com



www.national.com

**National Semiconductor
Americas Technical
Support Center**
Email: support@nsc.com
Tel: 1-800-272-9959

**National Semiconductor Europe
Technical Support Center**
Email: europe.support@nsc.com

**National Semiconductor Asia
Pacific Technical Support Center**
Email: ap.support@nsc.com

**National Semiconductor Japan
Technical Support Center**
Email: jpn.feedback@nsc.com